



## RECYFIX<sup>®</sup> NC

Extremely stable and lightweight -  
channels made for many industrial  
applications - to load class E600kN



# Contents

Product range		Loading category	Page
RECYFIX NC	Overview		<a href="#">3</a>
	Features & Benefits		<a href="#">4-5</a>
	Applications		<a href="#">6-7</a>
RECYFIX NC 100	Ductile iron gratings 4 bolt fixing Ductile iron gratings 8 bolt fixing	Class D400	<a href="#">8</a>
	Ductile iron gratings 4 bolt fixing Ductile iron gratings 8 bolt fixing	Class E600	<a href="#">9</a>
	Accessories - Trash boxes	Classes D400, E600	<a href="#">10</a>
	Accessories - End caps	N/A	
	Further accessories - Step fall adapter etc	N/A	<a href="#">11</a>
RECYFIX NC 150	Ductile iron gratings 8 bolt fixing Ductile iron gratings 4 bolt fixing	Class D400	<a href="#">12</a>
	Ductile iron gratings 8 bolt fixing Ductile iron gratings 4 bolt fixing	Class E600	
	Accessories - Trash boxes	Classes D400, E600	<a href="#">13</a>
	Accessories - End caps	N/A	
	Further accessories - sealing materials etc	N/A	
RECYFIX NC 200	Ductile iron gratings 8 bolt fixing Ductile iron gratings 4 bolt fixing	Class D400	<a href="#">14</a>
	Ductile iron gratings 8 bolt fixing Ductile iron gratings 4 bolt fixing	Class E600	
	Accessories - Trash boxes	Classes D400, E600	<a href="#">15</a>
	Accessories - End caps	N/A	
	Further accessories- sealing materials etc	N/A	
RECYFIX NC 300	Ductile iron gratings 8 bolt fixing	Class D400	<a href="#">16</a>
	Ductile iron gratings 8 bolt fixing	Class E600	
	Accessories - End caps	N/A	<a href="#">17</a>
	Further accessories- sealing materials etc	N/A	
RECYFIX NC 400	Ductile iron gratings 8 bolt fixing	Class D400	<a href="#">18</a>
	Accessories - End caps	N/A	<a href="#">19</a>
	Further accessories- sealing materials etc	N/A	

# RECYFIX® NC

**Extremely stable and lightweight** - channels made of robust reinforced PP.

## 1 Requirement

Modern drainage systems must

- withstand high loads and dynamic forces.
- be easy to install.
- be resistant to environmental influences (frost, heat, humidity).
- comply with EN 1433.

## 2 Application areas

- traffic areas for industry
- loading and unloading zones
- highly trafficked car parks
- public areas
- petrol stations

## 3 Solutions

RECYFIX NC channels:

- manufactured from reinforced PP
- load capacity up to E 600 according to EN 1433
- maximum security with 8 bolt fixing per metre
- very lightweight, quick and cost saving installation.

A selection of Hydraulic Performance tables for the most popular sizes of FASERFIX® and RECYFIX® channels including the RECYFIX® MONOTEC and RECYFIX® HICAP® ranges are available on request in an 8 page hard copy or PDF publication.

Hauraton channel drainage configurations are designed and sized using in-house **Hydraulic design software**. The accuracy of the software has been verified by physical testing of Hauraton systems within a hydraulic discharge test flume, replicating and evaluating hundreds of flow scenarios.

Hydraulic design software is also available free of charge to industry professionals. Intuitive and user friendly, **Hauraton Design Software** allows engineers to create drainage schemes for the company's range of civil engineering systems on tablets, desktop computers or through the internet (web-based application).

For smaller projects where a quick indication of the appropriate channel size and system is required for a given catchment area, Hauraton can provide their **Hydraulic Design App**.

For further details contact the Hauraton Technical Support Team



# Features and benefits of **RECYFIX®**NC channels

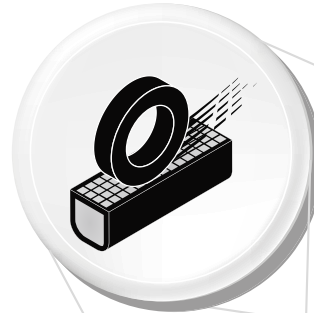

## high stability

- stable, durable ductile iron grating
- RECYFIX® NC 100, 200, 300: load class E 600
- RECYFIX® NC 400: load class D 400
- 8 bolts per metre fixing

= safety & durability



## standards and approvals

- certified to EN 1433
- CE-marking

= safety

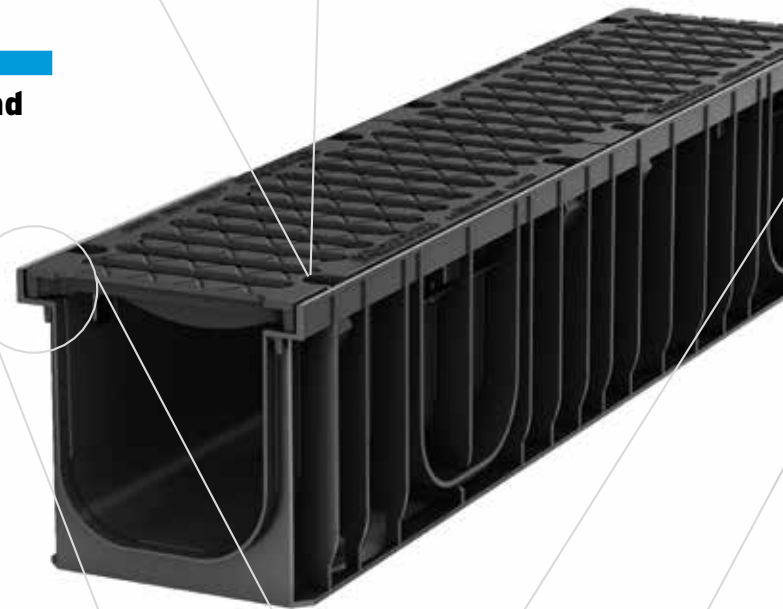

## low weight ensures easy handling on site

- much easier handling on site compared to channels made of polymer concrete
- simple installation
- maximum stability with minimum weight

= cost saving



## integrated angle housing

- angle housing acc. EN 1433
- angle housing is moulded as an integral part of the channel body (made of PP)
- ridges to stop any lateral movement

= safety



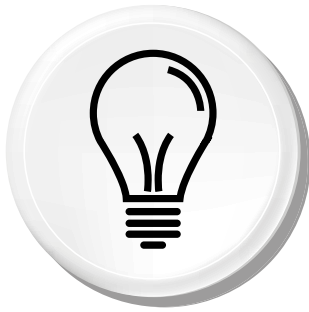

**continuous innovation**

- 20 years of experience
- unique material: 100 % recycled material

**= safety**

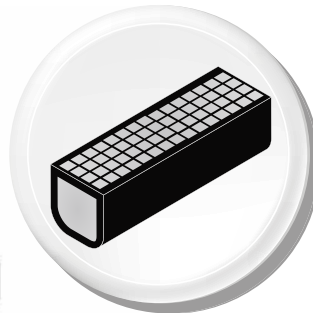

**prefabricated ready to install**

- channel and grating = one part
- no single parts
- easy handling in stock and on site
- cost-effective transportation

**= more earnings**

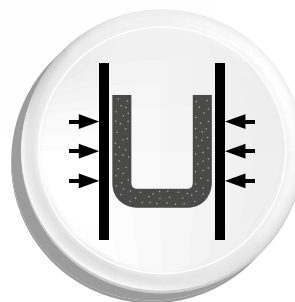

**high-grade material**

- RECYFIX - robust flexible and particularly resistant material
- withstands high traffic loads and temperature differences in daily use

**= safety & durability**

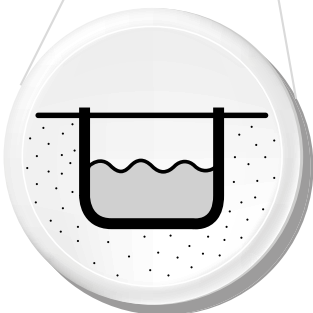

**high hydraulic capacity**

- drainage cross-section NC400= 1640 cm<sup>2</sup>
- more area per channel meter can be drained

**= safety**

Where channel gratings will not be trafficked a KTL electrostatic coating can be specified to prevent oxidation.

# RECYFIX<sup>®</sup> NC

Extremely stable and lightweight - channels made of reinforced PP.

RECYFIX NC channels meet the requirements of DIN EN 1433 and are suitable for the following load categories:



Category D 400,  
Load class 400 kN



Category E 600,  
Load class 600 kN

If in doubt, always select the higher class.

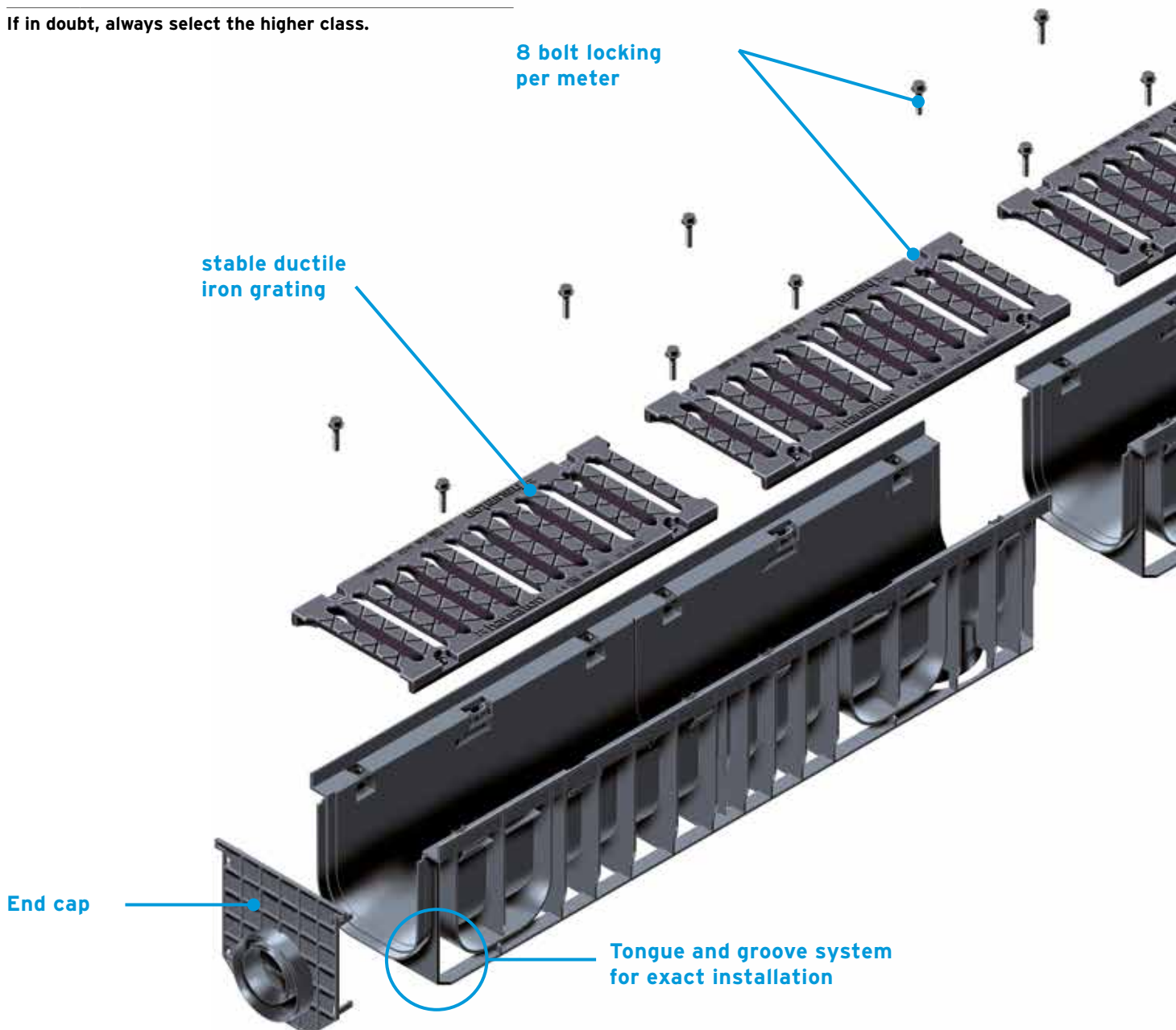

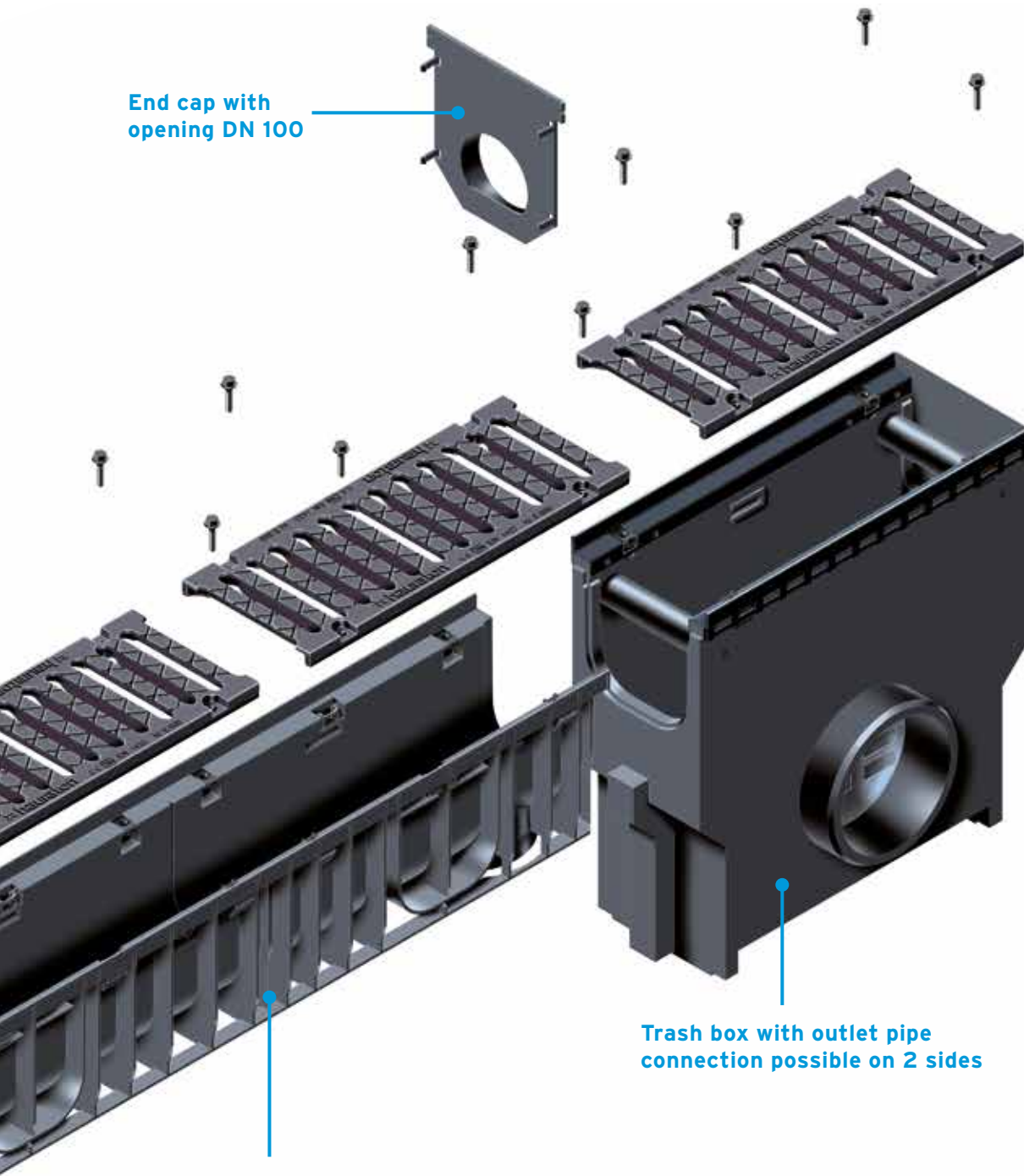

End cap with opening DN 100

Trash box with outlet pipe connection possible on 2 sides

channel are pre-assembled with gratings pre-fixed ready for installation on site

# RECYFIX®NC 100

## Combi article

### RECYFIX®NC 100, class D 400

8 bolt grating fixing per metre

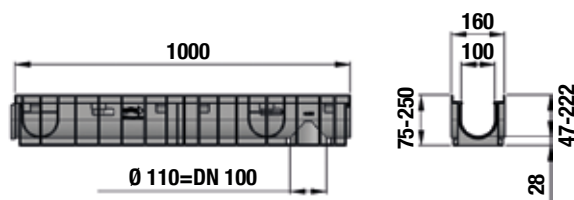
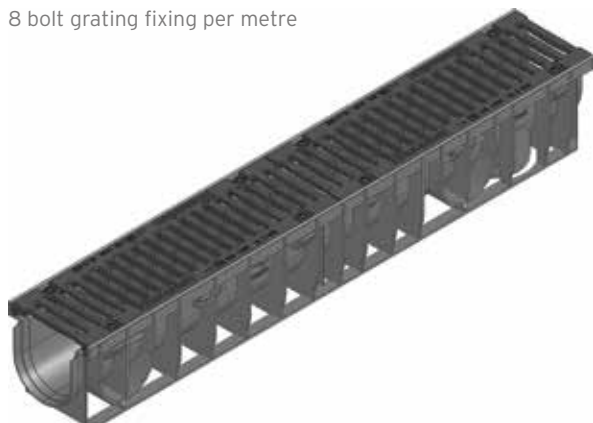

	Length mm	Width mm	Height mm	Invert mm	Drainage cross-sect. cm <sup>2</sup>	Intake cross-sect. cm <sup>2</sup> /m	Weight kg	Item No.
Type 01 with ductile iron grating, black, SW 10 mm, 8 bolt fixing	1000	160	150	122	92	427	10,7	48771
Type 0105 with ductile iron grating, black, SW 10 mm, 4 bolt fixing	500	160	150	122	92	427	5,4	48746
Type 010 with ductile iron grating, black, SW 10 mm, 8 bolt fixing	1000	160	200	172	142	427	11,6	48773
Type 01005 with ductile iron grating, black, SW 10 mm, 4 bolt fixing	500	160	200	172	142	427	5,8	48745
Type 020 with ductile iron grating, SW 10, black, 8 bolt fixing	1000	160	250	222	192	427	12,4	48777
Type 02005 with ductile iron grating, SW 10, black, 4 bolt fixing	500	160	250	222	192	427	6,2	48779
Type 75 with ductile iron grating, SW 10, black, 8 bolt fixing	1000	160	75	55	35	427	10,3	48775



Car Park



# RECYFIX<sup>®</sup>NC 100

## RECYFIX<sup>®</sup>NC 100, class E 600

8 bolt grating fixing per metre

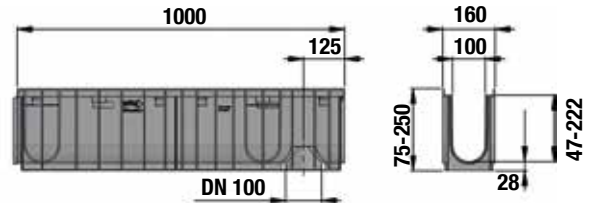
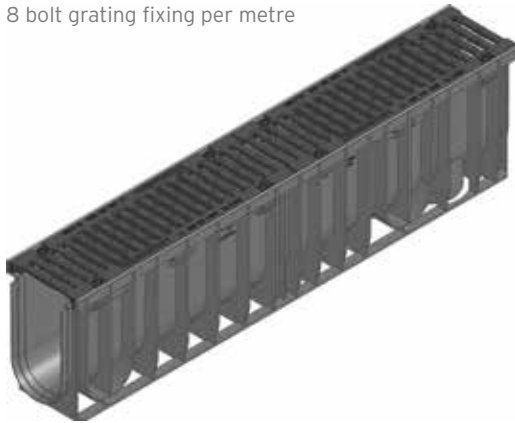

	Length mm	Width mm	Height mm	Invert mm	Drainage cross-sect. cm <sup>2</sup>	Intake cross-sect. cm <sup>2</sup> /m	Weight kg	Item No.
Type 01 with ductile iron grating, black, SW 10 mm, 8 bolt fixing	1000	160	150	122	92	427	10,7	48770
Type 0105 with ductile iron grating, black, SW 10 mm, 4 bolt fixing	500	160	150	122	92	427	5,4	48748
Type 010 with ductile iron grating, black, SW 10 mm, 8 bolt fixing	1000	160	200	172	142	427	11,6	48772
Type 01005 with ductile iron grating, black, SW 10 mm, 4 bolt fixing	500	160	200	172	142	427	5,8	48747
Type 020 with ductile iron grating, SW 10, black, 8 bolt fixing	1000	160	250	222	192	427	12,5	48776
Type 02005 with ductile iron grating, SW 10, black, 4 bolt fixing	500	160	250	222	192	427	6,2	48778
Type 75 with ductile iron grating, black, SW 10 mm, 8 bolt fixing	1000	160	75	55	35	427	10,2	48774



Industrial yard

# RECYFIX® NC 100

## Accessories

### Trash boxes

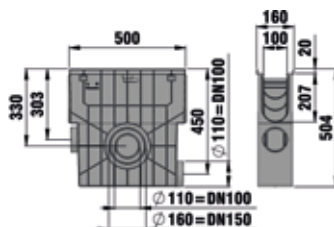

Trash box with plastic bucket, with ductile iron grating, black, SW 10 mm, class E 600, 4 bolt fixing

	Length mm	Width mm	Height mm	Weight kg	Item No.
Trash box with plastic bucket, with ductile iron grating, black, SW 10 mm, class D 400, 4-fold fixing	500	160	504	8,3	48754
Trash box with plastic bucket, with ductile iron grating, black, SW 10 mm, class E 600, 4-fold fixing	500	160	504	8,3	48753

### End caps



End cap closed



End cap with outlet DN 100

	Length mm	Width mm	Height mm	Weight kg	Item No.
End cap closed for type 01	-	160	124	-	48681
End cap with outlet DN 100 for type 01	-	160	200	0,1	48691
End cap closed for type 010	-	160	176	0,1	47082
End cap with outlet DN 100 for type 010	-	160	201	0,1	47093
End cap,closed for type 020	-	160	-	0,1	48683
End cap with outlet DN 100, type 020	-	160	-	0,1	48695
End cap closed for type 75	-	160	61	-	47097

# RECYFIX® NC 100

## Further accessories



Step Fall Adapter for step slope, from type 01 to type 010 (for RECYFIX NC and RECYFIX PRO also from type 010 to type 020)

	Length mm	Width mm	Height mm	Weight kg	Item No.
Step Fall Adapter for step slope, from type 01 to type 010 (for RECYFIX NC and RECYFIX PRO also from type 010 to type 020)	174	98	92	0,2	48790
RECYFIX sealing material, 290 ml	-	-	-	0,5	19053
RECYFIX primer, 250 ml	-	-	-	0,5	19054



Petrol Filling Station

# RECYFIX®NC 150

## Combi article

### RECYFIX®NC 150, class D 400

Type 01 with ductile iron grating, black,  
SW 18 mm, 8 bolts per metre fixing

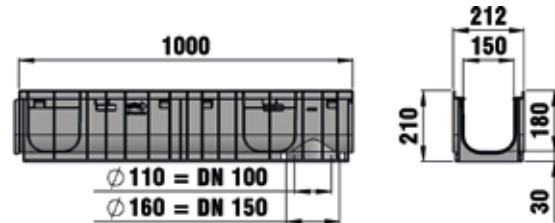
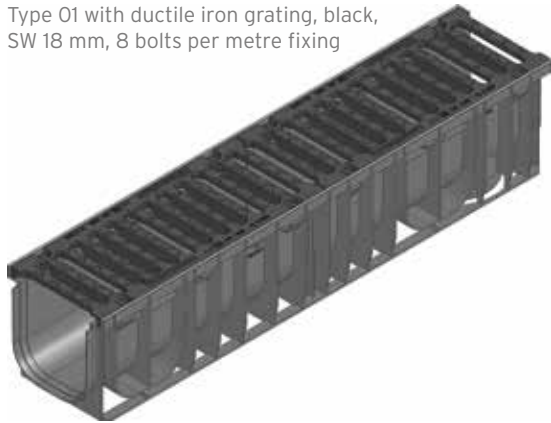

	Length mm	Width mm	Height mm	Invert mm	Drainage cross-sect. cm <sup>2</sup>	Intake cross-sect. cm <sup>2</sup> /m	Weight kg	Item No.
Type 01 with ductile iron grating, black, SW 18 mm, 8 bolt fixing	1000	212	210	180	230	702	15,7	48871
Type 0105 with ductile iron grating, black, SW 18 mm, 4 bolt fixing	500	212	210	180	230	702	7,9	48847

### RECYFIX®NC 150, class E 600

Type 01 with ductile iron grating, black,  
SW 18 mm, 8 bolts per metre fixing

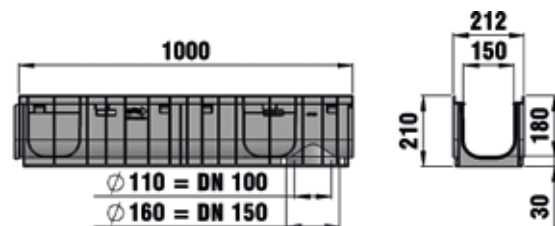
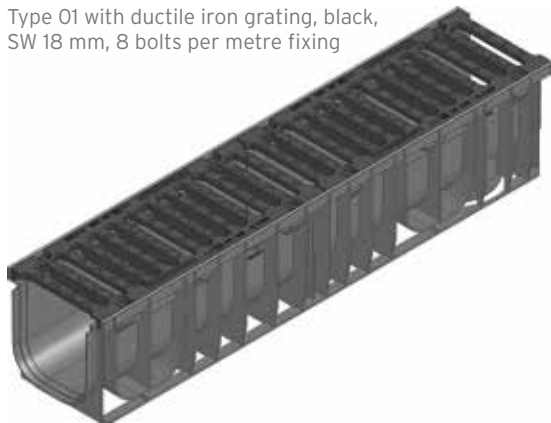

	Length mm	Width mm	Height mm	Invert mm	Drainage cross-sect. cm <sup>2</sup>	Intake cross-sect. cm <sup>2</sup> /m	Weight kg	Item No.
Type 01 with ductile iron grating, black, SW 18 mm, 8 bolt fixing	1000	212	210	180	230	702	15,7	48870
Type 0105 with ductile iron grating, black, SW 18 mm, 4 bolt fixing	500	212	210	180	230	702	7,9	48848

# RECYFIX® NC 150

## Accessories

### Trash boxes

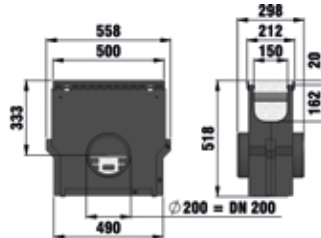

Trash box with plastic bucket, with ductile iron grating, black, SW 18 mm, class E 600, 4 bolt fixing

	Length mm	Width mm	Height mm	Weight kg	Item No.
Trash box with plastic bucket, with ductile iron grating, black, SW 18 mm, class E 400, 4 bolt fixing	500	212	518	22,9	48854
Trash box with plastic bucket, with ductile iron grating, black, SW 18 mm, class E 600, 4 bolt fixing	500	212	518	22,9	48853

### End caps



End cap combined, PP with outlet DN 70/100 for type 01

	Length mm	Width mm	Height mm	Weight kg	Item No.
End cap combined, PP with outlet DN 70/100 for type 01	-	210	218	0,2	40591

### Further accessories

	Length mm	Width mm	Height mm	Weight kg	Item No.
RECYFIX sealing material, 290 ml	-	-	-	0,5	19053
RECYFIX primer, 250 ml	-	-	-	0,5	19054

# RECYFIX<sup>®</sup>NC 200

## Combi article

### RECYFIX<sup>®</sup>NC 200, class D 400

Type 010 with ductile iron grating, black,  
SW 18 mm, 8 bolts per metre fixing

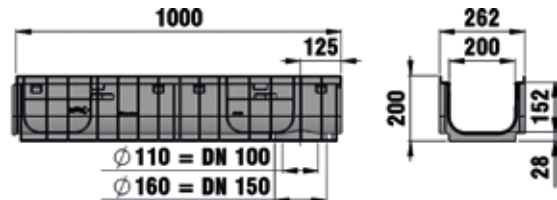
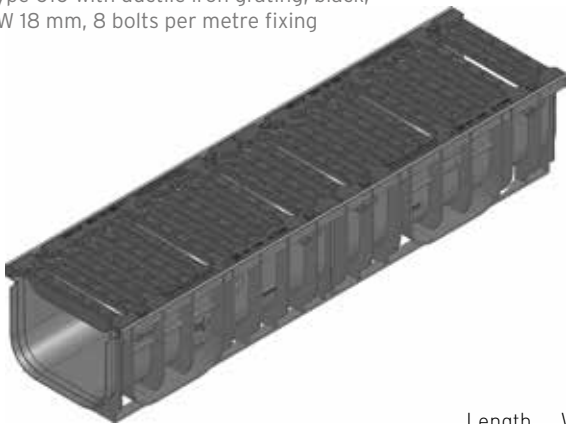

	Length mm	Width mm	Height mm	Invert mm	Drainage cross-sect. cm <sup>2</sup>	Intake cross-sect. cm <sup>2</sup> /m	Weight kg	Item No.
Type 010 with ductile iron grating, black, SW 18 mm, 8 bolt fixing	1000	262	200	172	294	936	20,8	49573
Type 01005 with ductile iron grating, black, SW 18 mm, 4 bolt fixing	500	262	200	172	294	936	10,4	49548

## Combi article

### RECYFIX<sup>®</sup>NC 200, class E 600

Type 010 with ductile iron grating, black,  
SW 18 mm, 8 bolts per metre fixing

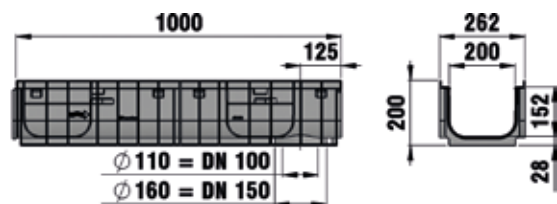
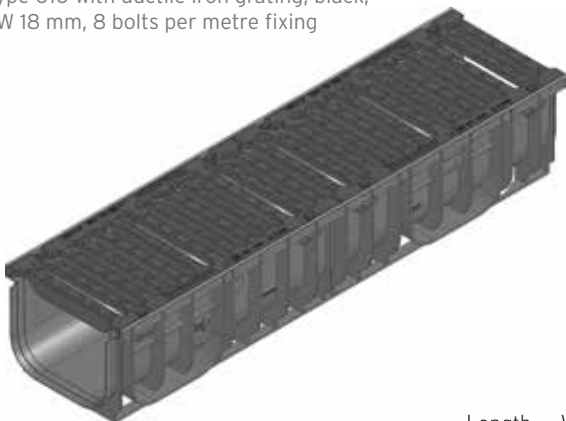

	Length mm	Width mm	Height mm	Invert mm	Drainage cross-sect. cm <sup>2</sup>	Intake cross-sect. cm <sup>2</sup> /m	Weight kg	Item No.
Type 010 with ductile iron grating, black, SW 18 mm, 8 bolt fixing	1000	262	200	172	294	936	20,8	49572
Type 01005 with ductile iron grating, black, SW 18 mm, 4 bolt fixing	500	262	200	172	294	936	10,4	49547

# RECYFIX<sup>®</sup> NC 200

## Accessories

### Trash boxes

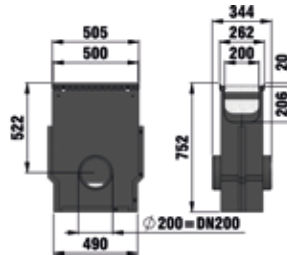

Trash box with plastic bucket, with ductile iron grating, black, SW 18 mm, class E 600, 4 bolts fixing

	Length mm	Width mm	Height mm	Weight kg	Item No.
Trash box with plastic bucket, with ductile iron grating, black, SW 18 mm, class E 400, 4 bolt fixing	500	262	752	35,2	49554
Trash box with plastic bucket, with ductile iron grating, black, SW 18 mm, class E 600, 4 bolt fixing	500	262	752	35,2	49553

### End caps



End cap combined made of PP closed / with outlet DN 100, Type 010

	Length mm	Width mm	Height mm	Weight kg	Item No.
End cap combined made of PP closed / with outlet DN 100, Type 010	-	258	217	0,2	41387

### Further accessories

	Length mm	Width mm	Height mm	Weight kg	Item No.
RECYFIX sealing material, 290 ml	-	-	-	0,5	19053
RECYFIX primer, 250 ml	-	-	-	0,5	19054

# RECYFIX®NC 300

## Combi article

### RECYFIX®NC 300, class D 400

Type 010 with ductile iron grating, black, SW 18 mm, 8 bolts per metre fixing

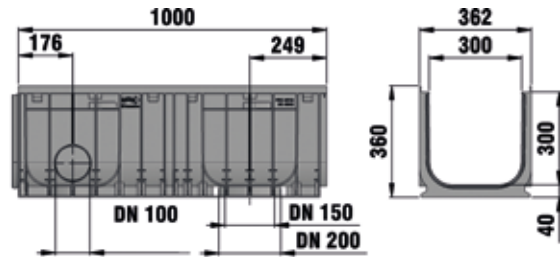
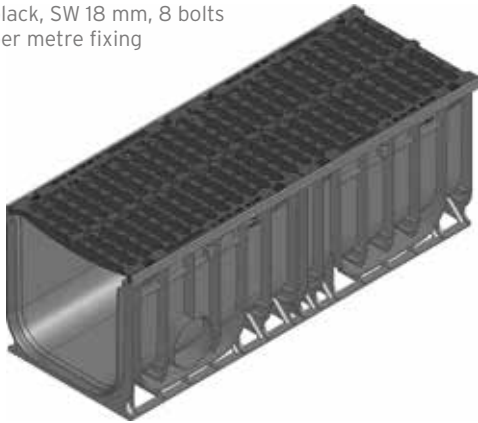

	Length mm	Width mm	Height mm	Invert mm	Drainage cross-sect. cm <sup>2</sup>	Intake cross-sect. cm <sup>2</sup> /m	Weight kg	Item No.
Type 010 with ductile iron grating, black, SW 18 mm, 8 bolt fixing	1000	362	360	320	873	1293	34,7	49873

### RECYFIX®NC 300, class E 600

Type 010 with ductile iron grating, black, SW 18 mm, 8 bolts per metre fixing

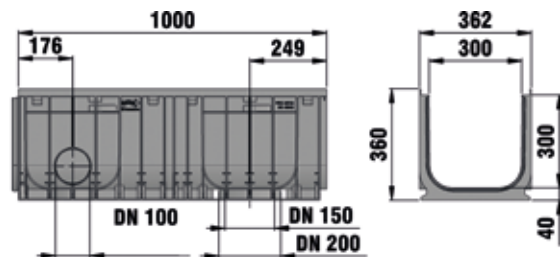
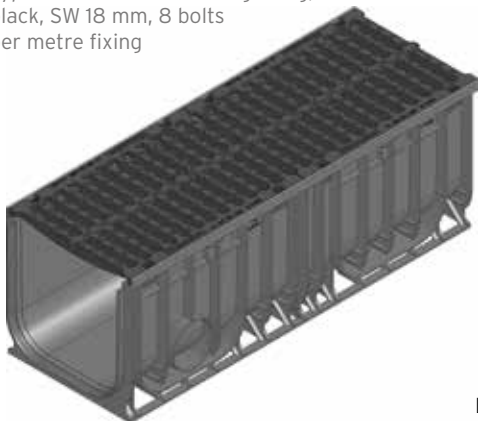

	Length mm	Width mm	Height mm	Invert mm	Drainage cross-sect. cm <sup>2</sup>	Intake cross-sect. cm <sup>2</sup> /m	Weight kg	Item No.
Type 010 with ductile iron grating, black, SW 18 mm, 8 bolt fixing	1000	362	360	320	873	1293	35,0	49872



# RECYFIX® NC 300

## Accessories

### Trash Boxes and End caps



end cap closed, galvanised, type 010

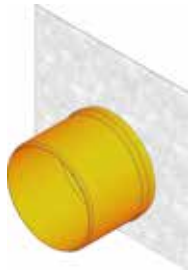

End cap with horizontal UPVC-outlet DN 200, galvanised, Type 010



Trash box with KTL galvanised angle housing with ductile iron grating SW 18mm Cl.E600

	Length mm	Width mm	Height mm	Weight kg	Item No.
End cap closed, galvanised, type 010	-	360	360	1,9	49783
End cap with horizontal UPVC-outlet DN 200, galvanised, Type 010	-	360	360	2,6	49791
Trash box with KTL coated galvanised angle housing with ductile iron grating SW 18mm, black cl. D 400, locked with galvanised bucket, with PVC-U pipe outlet DN/OD 200	500	362	862	50,46	32330
Trash box with KTL coated angle housing with ductile iron grating SW 18mm, black, cl. D 400, locked, with galvanised bucket, with PVC-U pipe outlet DN/OD 315	500	362	862	50,46	32337
Trash box with KTL coated galvanised angle housing with ductile iron grating SW 18mm, black, cl. E 600, locked, with galvanised bucket, with PVC-U pipe outlet DN/OD 200	500	362	862	50,47	32331
Trash box with KTL coated angle housing with ductile iron grating SW 18mm, black, cl. E 600, locked, with galvanised bucket, with PVC-U pipe outlet DN/OD 315	500	247	862	50,47	32338

### Further accessories

	Length mm	Width mm	Height mm	Weight kg	Item No.
RECYFIX sealing material, 290 ml	-	-	-	0,5	19053
RECYFIX primer, 250 ml	-	-	-	0,5	19054

# RECYFIX®NC 400

## Combi article

### RECYFIX®NC 400, class D 400

Type 010 with ductile iron grating, black, SW 18 mm, 8 bolt per metre fixing

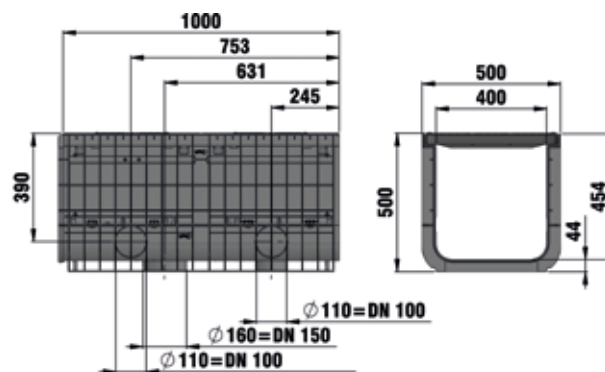
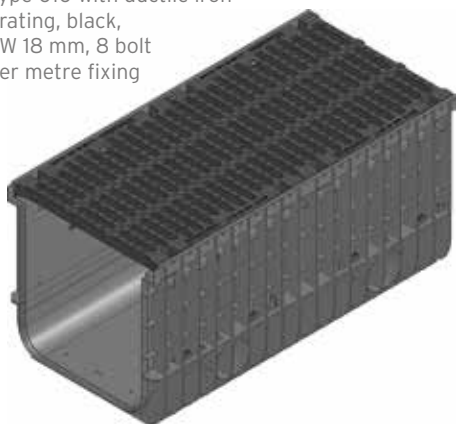

	Length mm	Width mm	Height mm	Invert mm	Drainage cross-sect. cm <sup>2</sup>	Intake cross-sect. cm <sup>2</sup> /m	Weight kg	Item No.
Type 010 with ductile iron grating, black, SW 18 mm, 8 bolt fixing	1000	500	500	456	1640	1753	57,2	42421



# RECYFIX®NC 400

## Accessories

### End caps



End cap closed, type 010

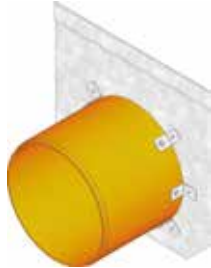

End cap with horizontal UPVC - outlet DN 300, type 010

	Length mm	Width mm	Height mm	Weight kg	Item No.
End cap closed, type 010	-	500	498	3,1	42481
End cap with horizontal UPVC - outlet DN 300, type 010	-	500	498	4,9	42487

### Further accessories

	Length mm	Width mm	Height mm	Weight kg	Item No.
RECYFIX sealing material, 290 ml	-	-	-	0,5	19053
RECYFIX primer, 250 ml	-	-	-	0,5	19054

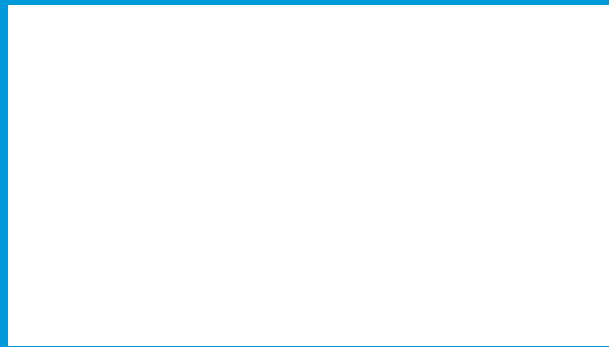

08/2019 |  
All drawings, measurements and weights  
are non-committal! We reserve the right to  
do technical changes for improvement

#### HAURATON LIMITED

Unit 4, Frenchs Avenue  
Dunstable, Bedfordshire  
LU6 1BH

Tel. 01582 501380  
Fax 01582 501399  
TS-UK@hauraton.com  
[www.hauraton.co.uk](http://www.hauraton.co.uk)

